

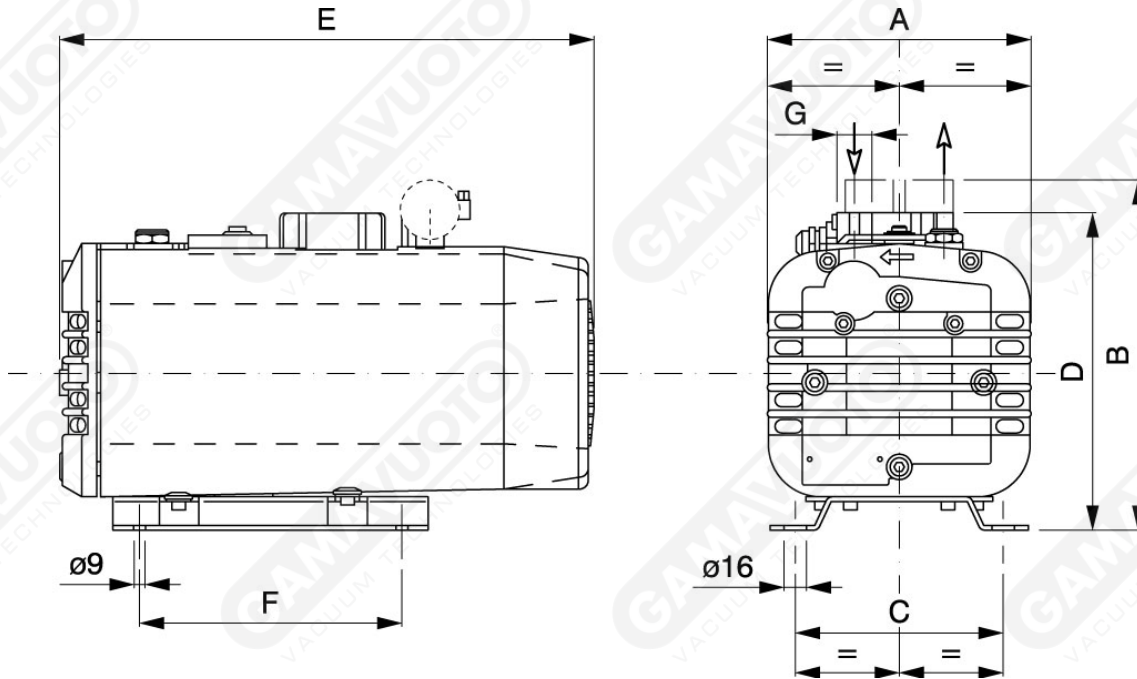

Trockenläufer Pumpen GPZS 16-40



Art. GPZS 16/25/40

Art.	Vakuum-Durchsatz		Enddruck mbar (ass.)	Geschwindigkeit		Motorleistung		Gewicht kg	A	B	C	D	E	F	G
	50 Hz Mc/h	60 Hz Mc/h		50 Hz g/min	60 Hz g/min	50 Hz Kw	60 Hz Kw								
GPZS 16	16	19	120	1400	1700	0.75	0.90	33	206	271	160	244	412	202	1/2"
GPZS 25	25	29	120	1400	1700	0.75	0.90	32.5	206	271	160	244	412	202	3/4"
GPZS 40	40	48	120	1400	1700	1.3	1.5	45	230	309	160	294	485	202	1"